

---

# Northeast Boundary Tunnel Project Tunnel Forum

*4th Street NE and Rhode Island Avenue NE Construction Sites*

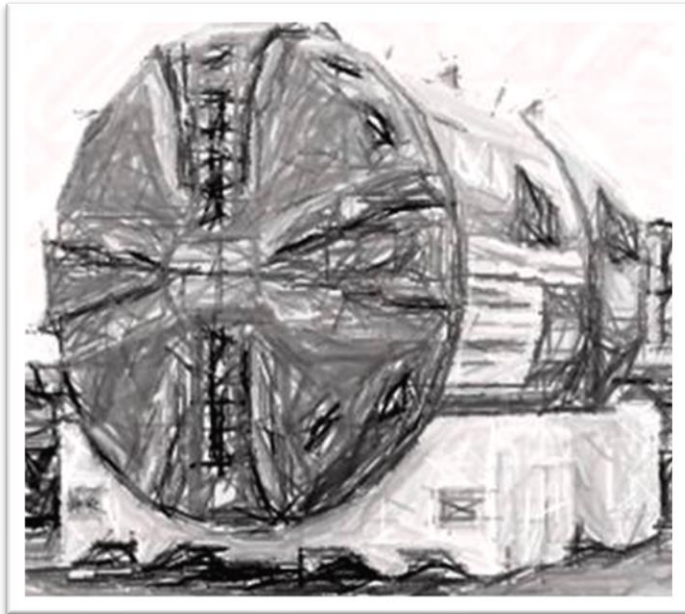

**Thursday, April 22, 2021  
Zoom Meeting**

# Welcome to the Tunnel Forum Virtual Meeting!



## Participation Tips:

- Online meetings are subject to your bandwidth limitations. If your connection to the meeting should freeze, please exit and reenter the meeting to refresh your connection.
- Participants may opt to turn on or off your video.
- All participant lines are muted to minimize disruptions.
- The Questions and Answers period will be held at the end of the presentation. [Please hold your questions until the Q&A portion of the meeting.](#)
- During the Question and Answer period of the meeting, we will acknowledge questions from participants who are online and on phone.
- **ONLINE PARTICIPANTS:** send your questions to the Host by using the Chat mode. You may also click on “Participants” to raise your hand for a question.
- **PHONE PARTICIPANTS:** press \*9 to alert us that you want to ask a question. We will unmute you when it’s your turn to ask a question.

# Agenda

---

- **Safety First**
  - **Project Overview**
  - **Responses to Community Concerns**
  - **4th Street NE Construction Site**
  - **Rhode Island Avenue NE Construction Site**
  - **NEBT Claims Process**
- **Rhode Island Avenue NE Main Street Partnership-Business**
  - **Questions and Answers**
  - **Contact Us**

# We Want Everyone To Be Safe

Alan Etter

---



The city's response to Covid-19 is evolving. To see more on the city's response, go to [coronavirus.dc.gov](https://coronavirus.dc.gov). For coronavirus testing in DC, call 1-855-363-0333.

**The NEBT Team has taken the following actions to ensure the safety of employees:**

- Employees in the tunnel must undergo temperature screening at the start of their shift
- Masks and other personal protective equipment must be worn by all employees on site
- Employees maintain at least six feet of distance when possible whether on above or below ground operations
- All shared tools & equipment are regularly sanitized
- Please let us know how to make our engagement with you better

## **Outreach During Quarantine**

Our team continues to engage the community through virtual meetings, email, door-to-door newsletter distribution (when necessary) and can be reached by email at [dccleanrivers@dcwater.com](mailto:dccleanrivers@dcwater.com) and by calling the NEBT Hotline at 1-800-988-6151.

# Northeast Boundary Tunnel Project: Benefits

## William Levy

- Reduce the frequency and magnitude of street flooding
- Significantly mitigate the frequency, magnitude, and duration of sewer flooding and basement backups in the Northeast Boundary drainage area
- Reduce risks to human health
- Control \*combined sewer overflow (CSO) discharges to the Anacostia River, significantly improving water quality
- Prevent deterioration of historic resources from water damage caused by flooding

\* CSO = Combined Sewer Overflows.  
Learn more at [dcwater.com/css](https://dcwater.com/css).

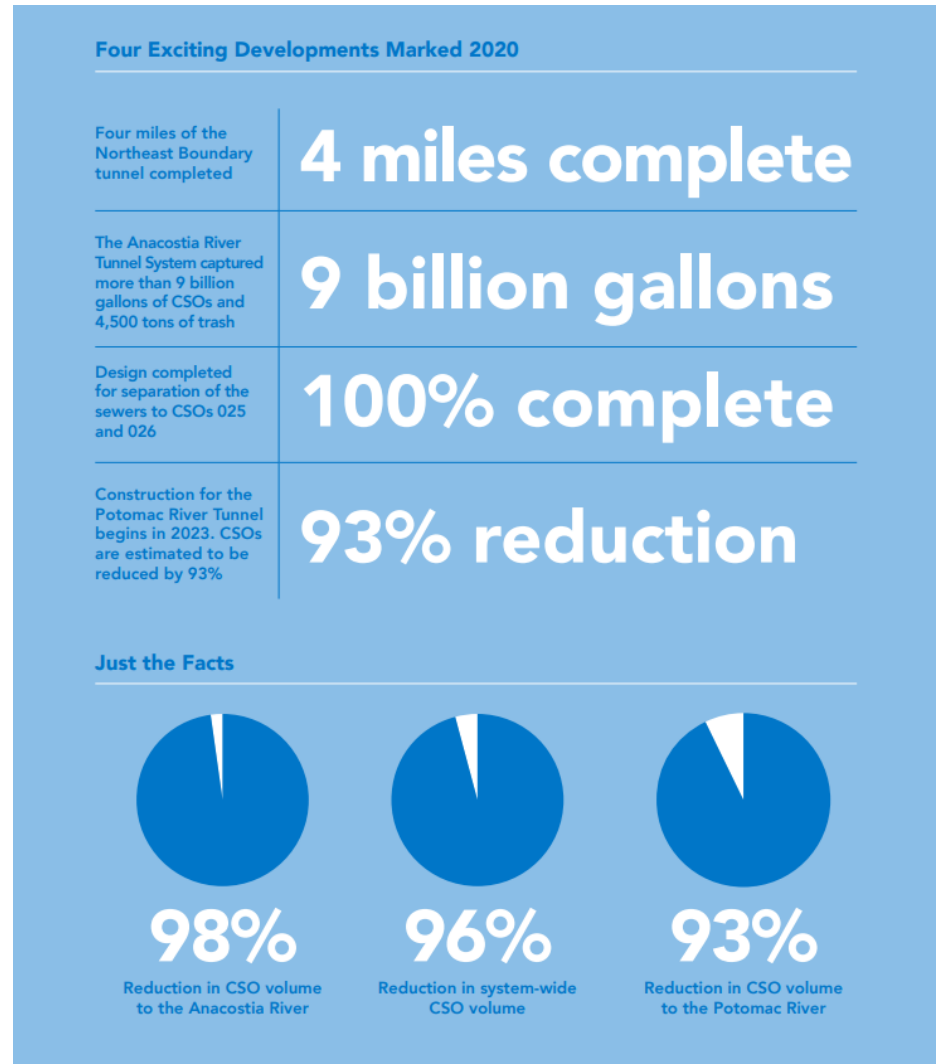

Source: [annual\\_report\\_2020.pdf](https://dcwater.com/annual_report_2020.pdf) ([dcwater.com](https://dcwater.com))

# Good News – Chris Completes His Journey!

## William Levy

- Chris the Tunnel Boring Machine broke through the drop shaft at 6th & R Streets NW on Wednesday, April 21, 2021.
- Completed 27,000 feet (5 mi.) of tunnel
- Connecting to Anacostia River Tunnel & First Street Tunnel (ongoing)



PLAN

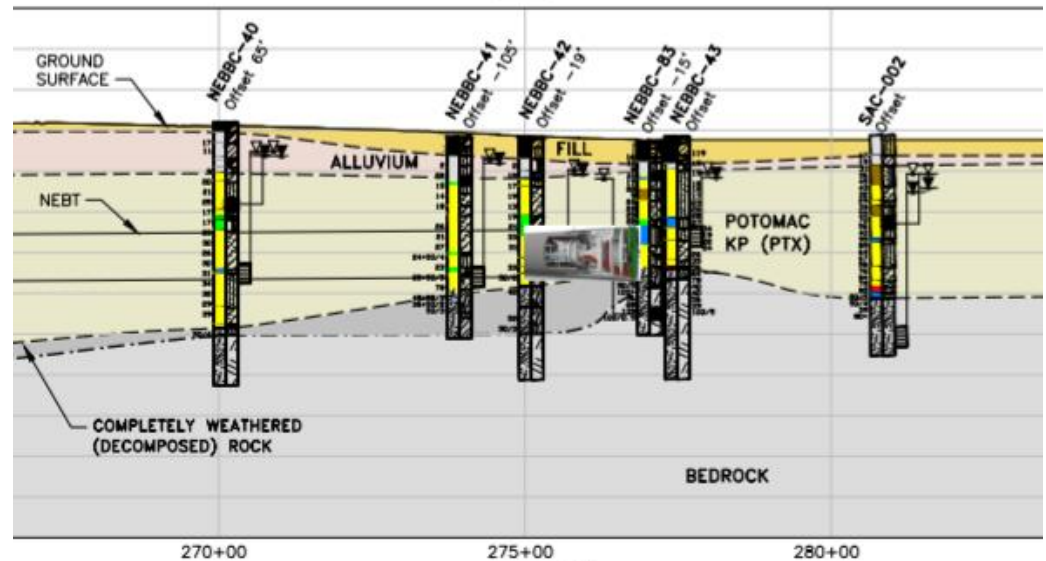

# Responses to Community Concerns

## Hadiyah Jordan

---

CONCERN	RESPONSE
Will 3 <sup>rd</sup> and 4 <sup>th</sup> Street return to two-way traffic? Will all traffic and pedestrian signs be removed at the end of the project?	Both 4 <sup>th</sup> and 3 <sup>rd</sup> Streets will be returned to two-way traffic. All signs associated with the project will be removed. However, the 'No Trucks Over ¼ Ton' signs can remain if the neighborhood would like.
When will be the last day of construction in front of the BP Gas Station?	We are scheduled to relocate the 4 <sup>th</sup> Street NE Construction Site fencing in the late Summer or early Fall of 2021
There is a large manhole cover located in the one lane of 4th Street NE and when a car or truck or bus drives over it, it makes a loud clanking sound.	The construction team identified the manhole and reduced the noise by cleaning the frame and resetting the cover.
Please repair the traffic signage that have fallen and have rotten bases, disintegrated sand-bags, and have been a trip hazard to neighbors.	The signs have been repaired.

# Construction Site Updates

## Gianluca Pianezze and Matt Wolniak

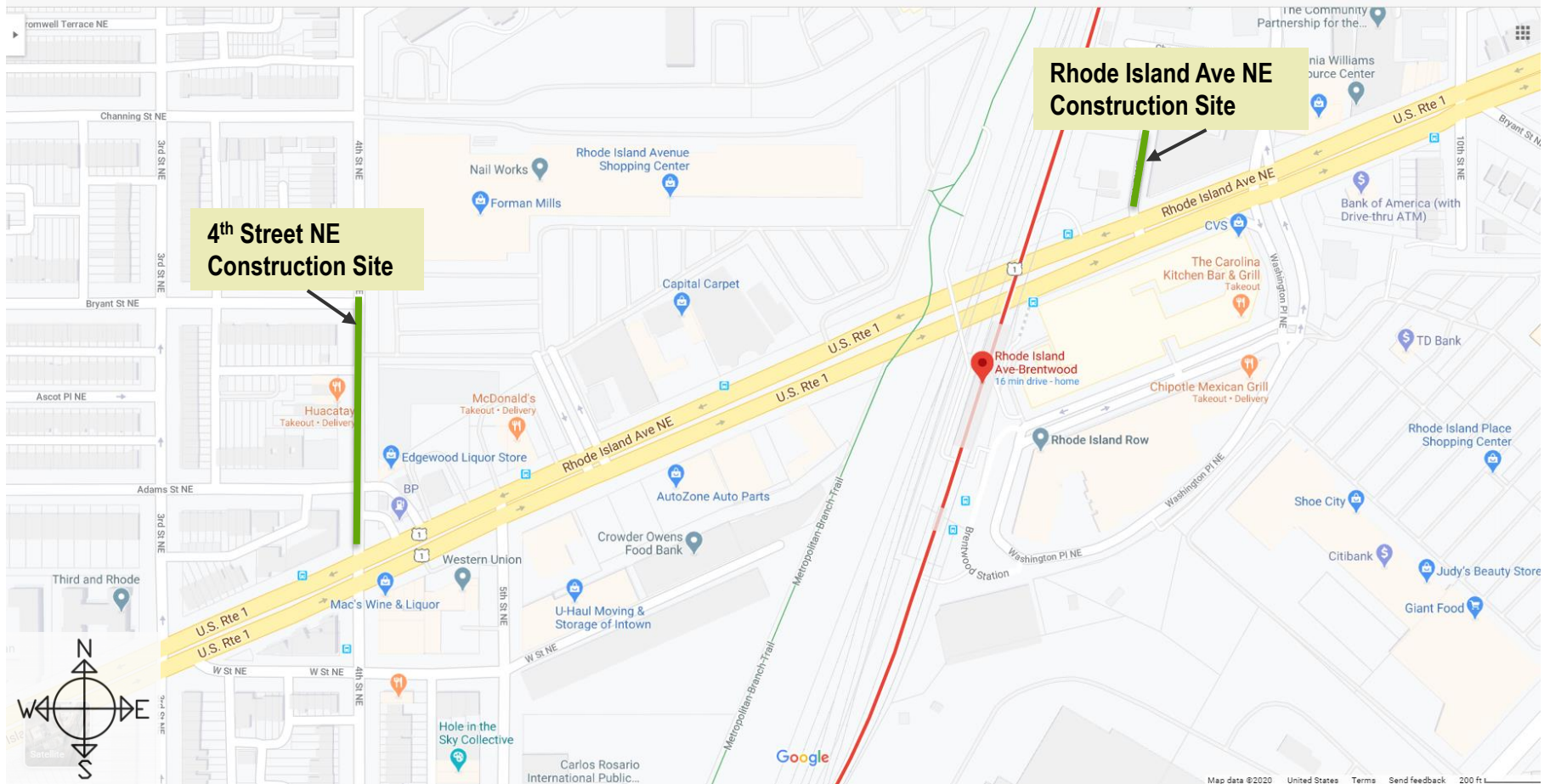

— The green line = the Construction Site locations.



# 4<sup>th</sup> Street NE Construction Site Map

Gianluca Pianezze

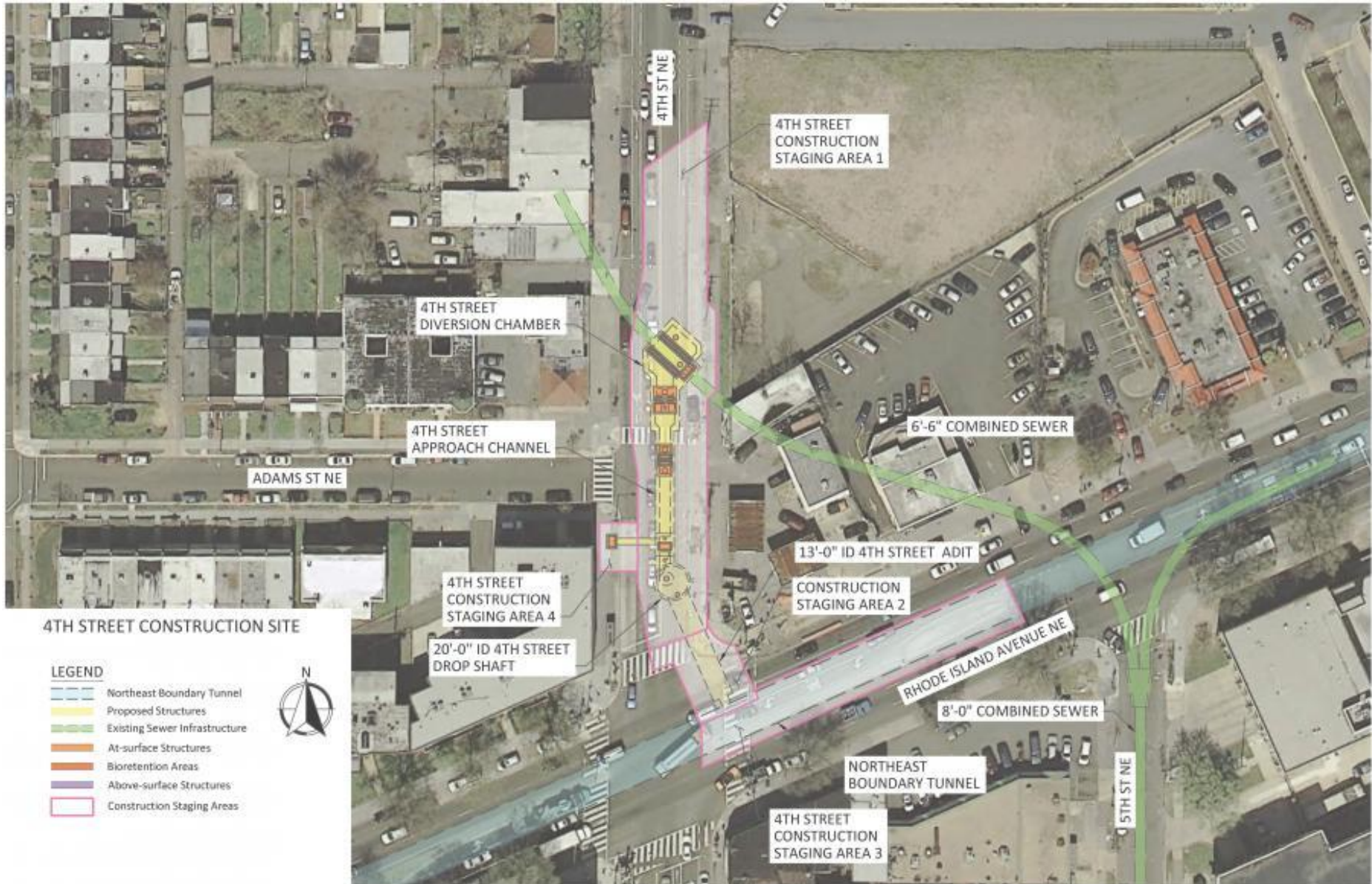

# 4<sup>th</sup> Street NE Construction Site

## Gianluca Pianezze



### CONSTRUCTION WORK HOURS

Monday – Friday	7:00 AM to 7:00 PM
Saturday	7:00 AM to 5:00 PM
Construction End Date	January 2022 for completion of construction and restoration

All construction dates are approximate and could change.

# What's Completed at the 4th Street Site

## Gianluca Pianezze

- **Adit:** Completed excavation and concrete liner. The adit is a small tunnel.
- **Drop Shaft:** Completed excavation to 115 ft deep with inside diameter of 24.5 ft.
- **Approach Channel:** Completed excavation
- **Diversion Chamber:** Completed concrete walls and roof slab

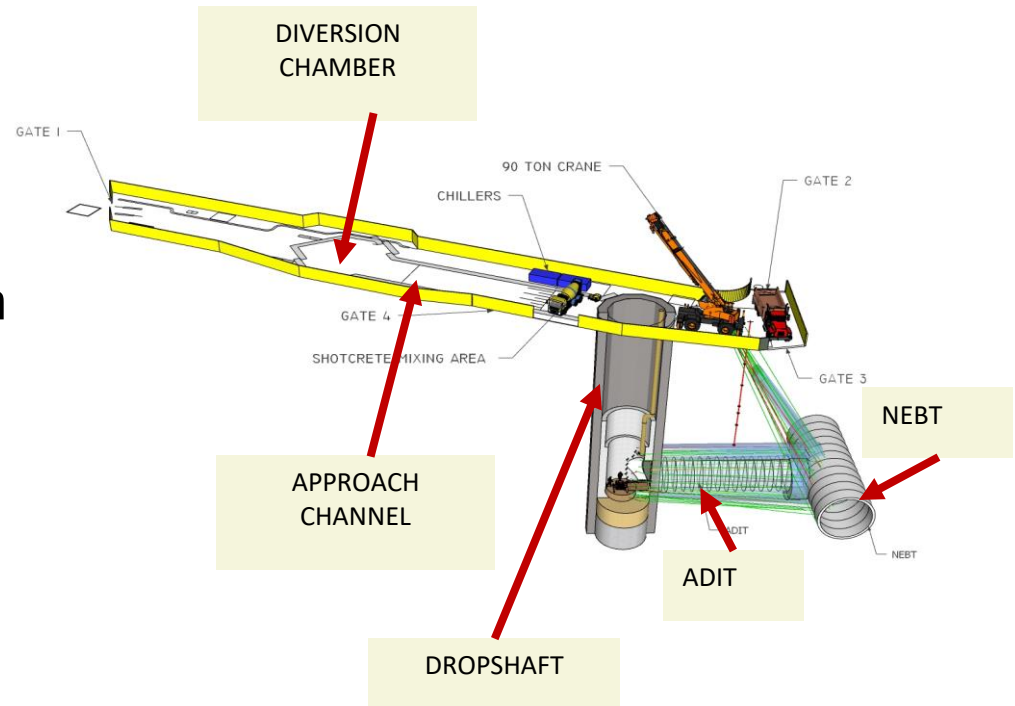

Map of the diversion facility at the 4<sup>th</sup> Street NE Construction Site

# Construction Activity at the 4th Street Site

## Gianluca Pianezze

- **Adit:** Constructing the interior ventilation pipe
- **Drop Shaft:** Constructing the internal concrete drop pipe for flow and ventilation riser pipe
- **Approach Channel:** Casting in place the concrete structure



Setting forms for the approach channel base.



Inspecting the interior of the drop shaft.

# Restoration Work at the 4<sup>th</sup> Street Site

David Leuth

---

- New roadway paving and markings
- Sidewalks and curbs
- Reconstruct the Medians
- Replant Trees
- Restore Tree Boxes and Add Decorative Iron Fencing
- Adjust Signalization
- Return Bus Stops to the Original Location

Scheduling restoration work is partially determined by the weather and temperature.

**In the late fall of 2021 partial restoration will begin when we switch traffic to the opposite site of 4th Street NE.**

# 4<sup>th</sup> Street NE Construction Site: Traffic Pattern

## Matt Wolniak

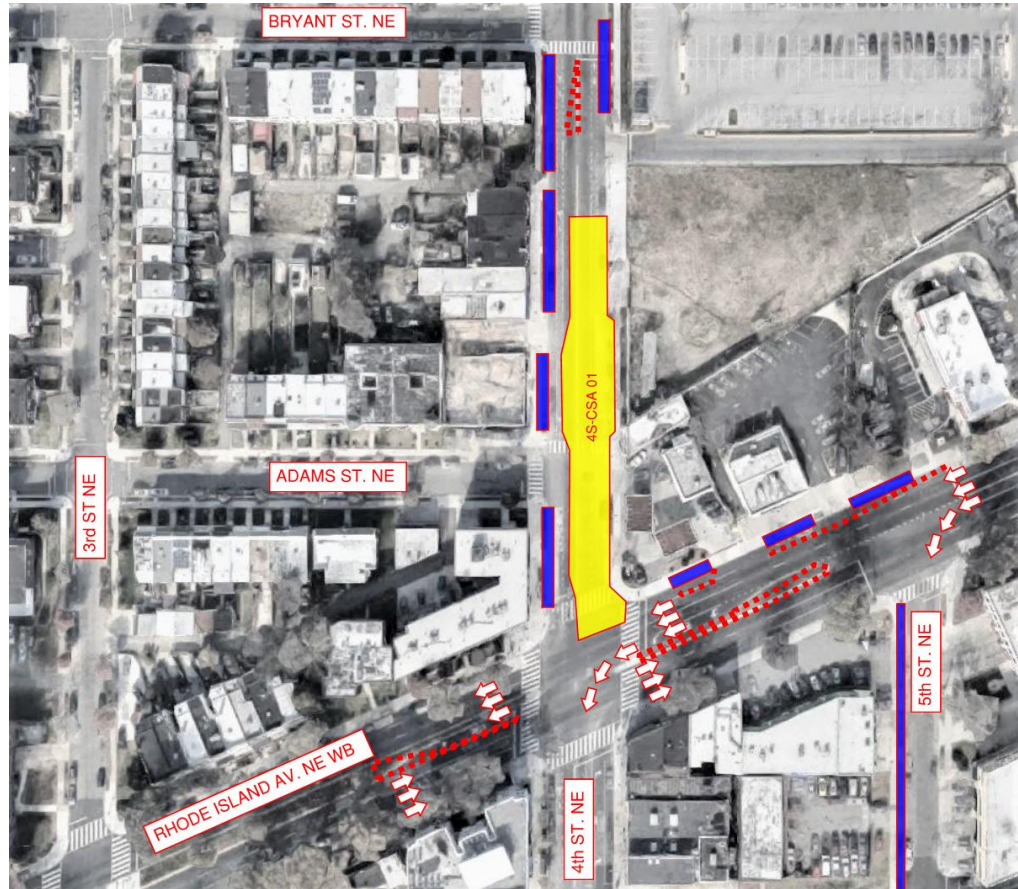

### 4<sup>TH</sup> STREET NE CONSTRUCTION SITE

TRAFFIC PATTERN:

The traffic pattern will change in 2021.

MAIN IMPACT:

4<sup>th</sup> Street NE closed to northbound traffic between Rhode Island Avenue NE and Bryant Street NE.

# 4<sup>th</sup> Street NE Construction Site: Pedestrian Detour

## Matt Wolniak



### 4<sup>TH</sup> STREET NE CONSTRUCTION SITE – Pedestrian Detour

PEDESTRIAN DETOUR:	The pedestrian detour will continue into 2021.
MAIN IMPACT:	Pedestrian path provided around the construction site.

# Rhode Island Avenue NE Construction Site Map

## Gianluca Pianezze

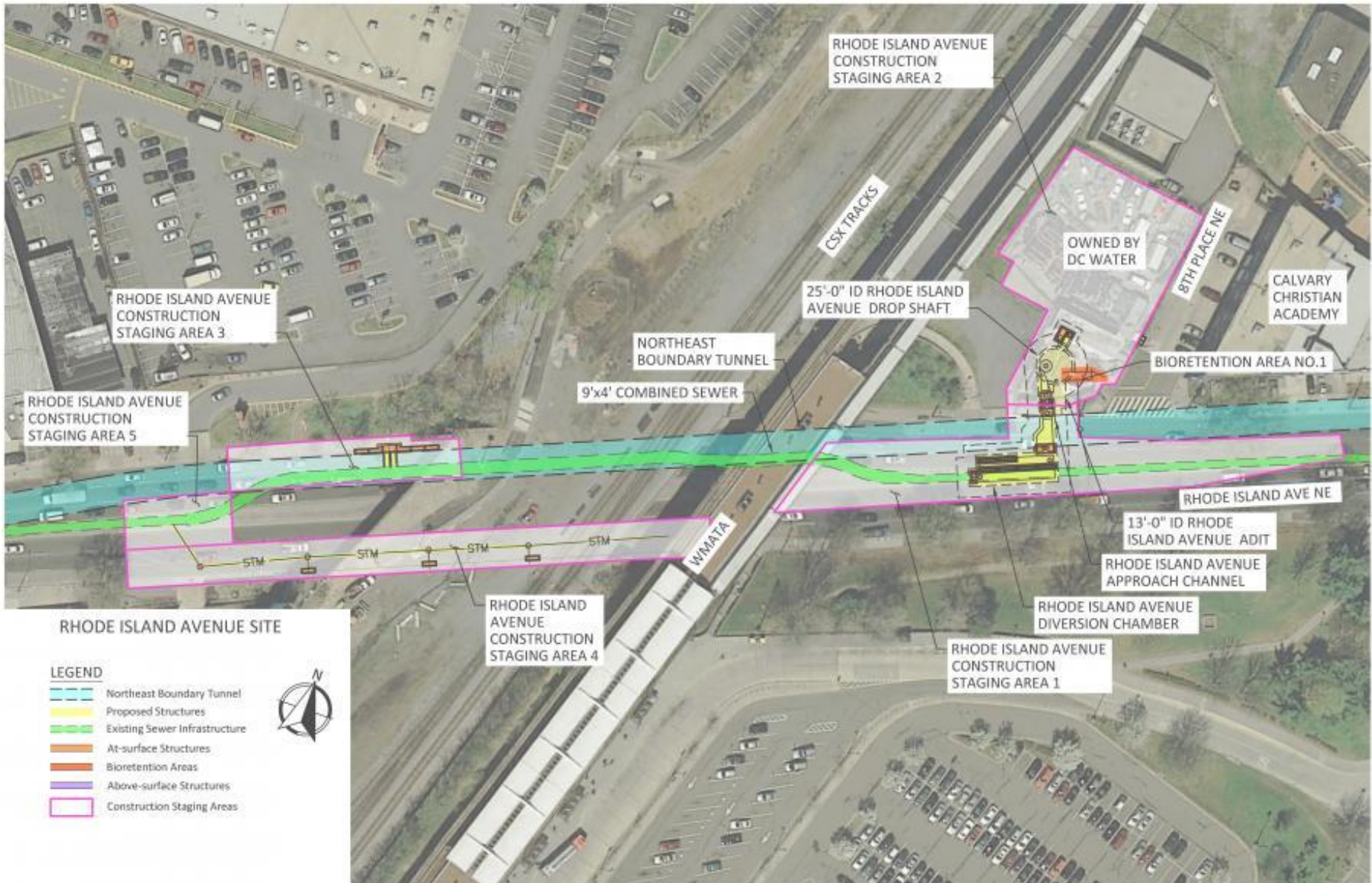



# Rhode Island Avenue NE Construction Site

## Gianluca Pianezze



### CONSTRUCTION WORK HOURS

Monday - Friday	7:00 AM to 7:00 PM
Saturday (occasionally)	7:00 AM to 5:00 PM
Construction End Date	Fall 2022

All construction dates are approximate and could change.

# What's Completed at the Rhode Island Ave NE Site

## Gianluca Pianezze

- **Drop Shaft:** Completed excavation to 110 ft deep and inside diameter of 25 ft.
- **Approach Channel:** Completed support of excavation and ground improvement
- **Diversion Chamber:** Completed support of excavation and ground improvement

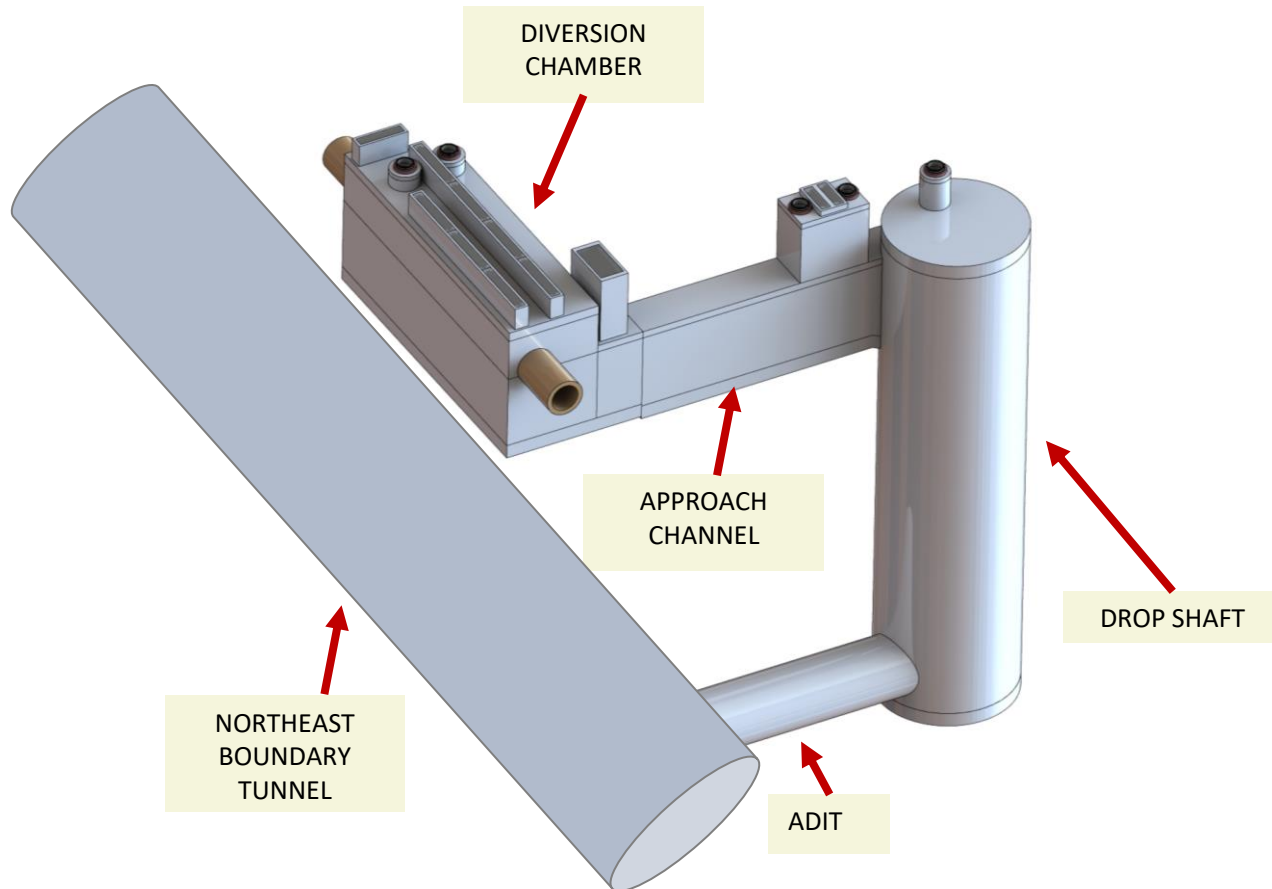

Map of the diversion facility at the Rhode Island Ave NE Construction Site

# Construction Activity at the Rhode Island Ave NE Site

## Gianluca Pianezze

- **Drop Shaft:** Installing the permanent concrete liner
- **Diversion Chamber.** Excavating in median area of Rhode Island Avenue NE

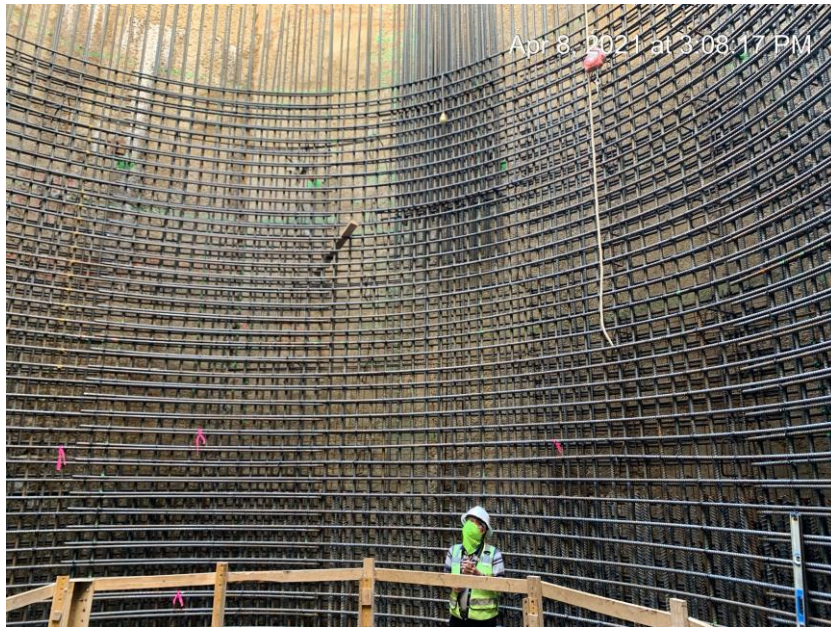

Installing rebar inside drop shaft to line the walls with concrete.



Lining the jersey barriers in preparation for changing the traffic pattern .

# Rhode Island Ave NE Construction Site: Traffic Pattern

## Matt Wolniak

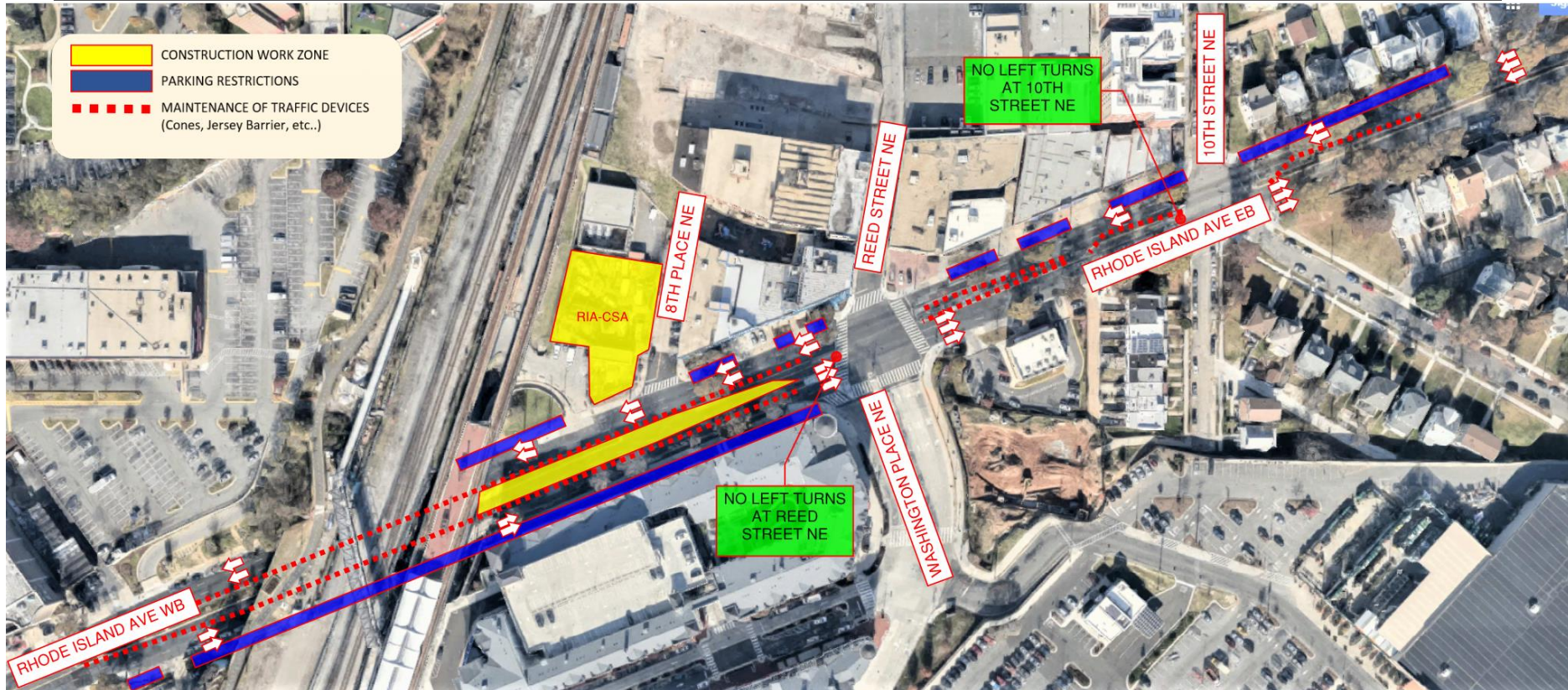

### RHODE ISLAND AVENUE NE CONSTRUCTION SITE

TRAFFIC PATTERN:

The traffic pattern on Rhode Island Avenue NE.

MAIN IMPACT:

Two lanes in each direction on Rhode Island Avenue NE routed to go around the construction area in middle lanes. **No left turns permitted from eastbound Rhode Island Ave to Reed Street and 10<sup>th</sup> Street.**

# NEBT Claims Process

## Garry Brennan

---

- If you are a property owner and you believe that construction activities undertaken as a result of this project have damaged your property in some way, you may send an **email** to [dccleanrivers@dcwater.com](mailto:dccleanrivers@dcwater.com) or **call the Hotline** at 800-988-6151.
- A representative of the contractor, SIH, will contact you to receive the information for the claim. A claim will be initiated on your behalf and a copy will be transmitted to you. Further communications about the claim will occur between the property owner and DC Water's insurance company.
- The claim receives a claim number, and an adjuster investigates.
- It is recommended that when you see damage, report it.

# We LOVE Our Local Businesses

## Bill Levy



# We LOVE Our Local Businesses

## Bill Levy

---



- Staff Appreciation Lunch events with meals purchased from area restaurants. 171 meals served so far!
- Encourages patronage of affected businesses.

# Rhode Island Avenue NE Main Street

Bill Levy

---

**Kyle Todd, Executive Director**

Office Location

2300 Rhode Island Avenue NE,  
Suite 202

[kyle@riainmainstreet.org](mailto:kyle@riainmainstreet.org)

202-808-9050

[riainmainstreet.org](http://riainmainstreet.org)





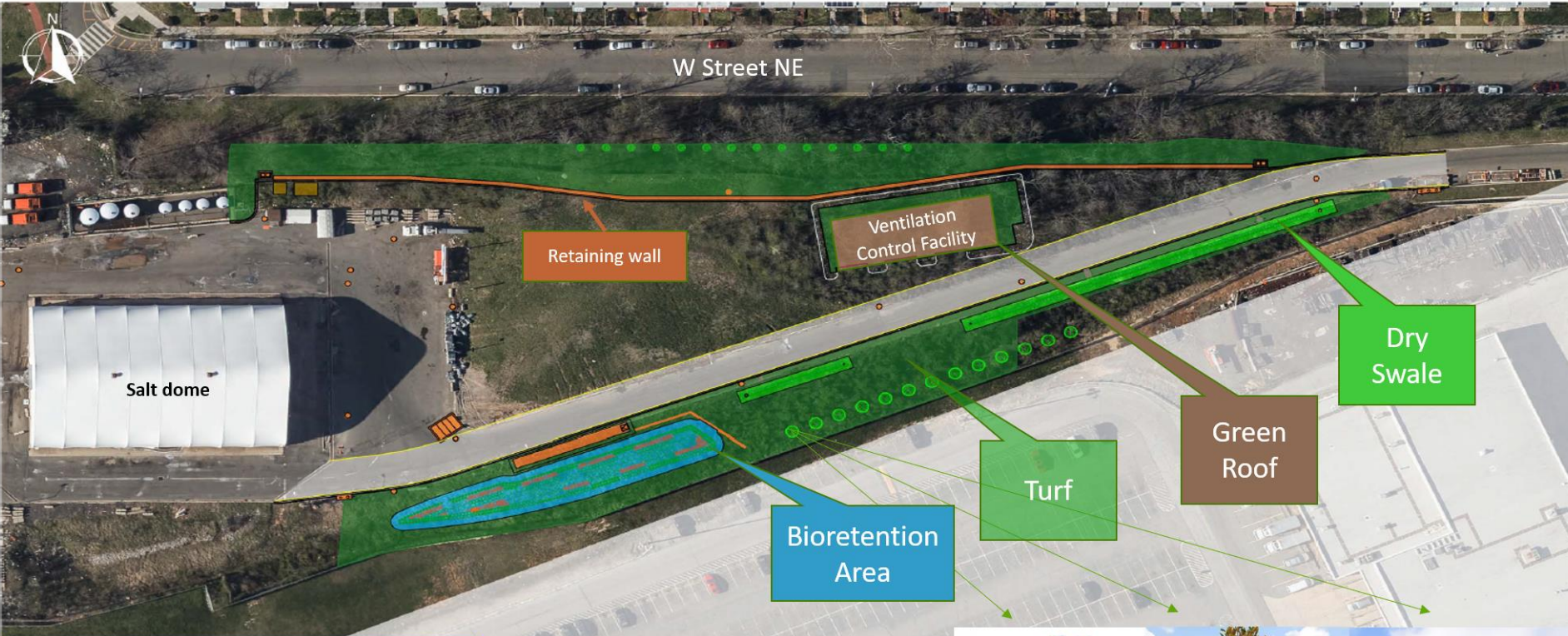

**W STREET NE CONSTRUCTION SITE**

When the Northeast Boundary Tunnel construction is complete the new Green Infrastructure at DPW will help reduce surface runoff from entering the sewer system.

**24 New Trees**



Follow Chris the TBM on Twitter: [@Chris\\_TBM](https://twitter.com/Chris_TBM)



To receive email updates about NEBT construction, send an email to [dccleanrivers@dcwater.com](mailto:dccleanrivers@dcwater.com).

**For More Info**

- **24/7 NEBT Hotline:** (800) 988-6151
- **Email:** [dccleanrivers@dcwater.com](mailto:dccleanrivers@dcwater.com)
- **Project Webpage:** [dcwater.com/NEBT](http://dcwater.com/NEBT)

We will acknowledge questions from participants who are online and on the phone.



- **ONLINE PARTICIPANTS:** send your questions to the Host by using the Chat mode. You may also click on “Participants” to raise your hand for a question.
- **PHONE PARTICIPANTS:** press \*9 to alert us that you want to ask a question. We will unmute you when it’s your turn to ask a question.